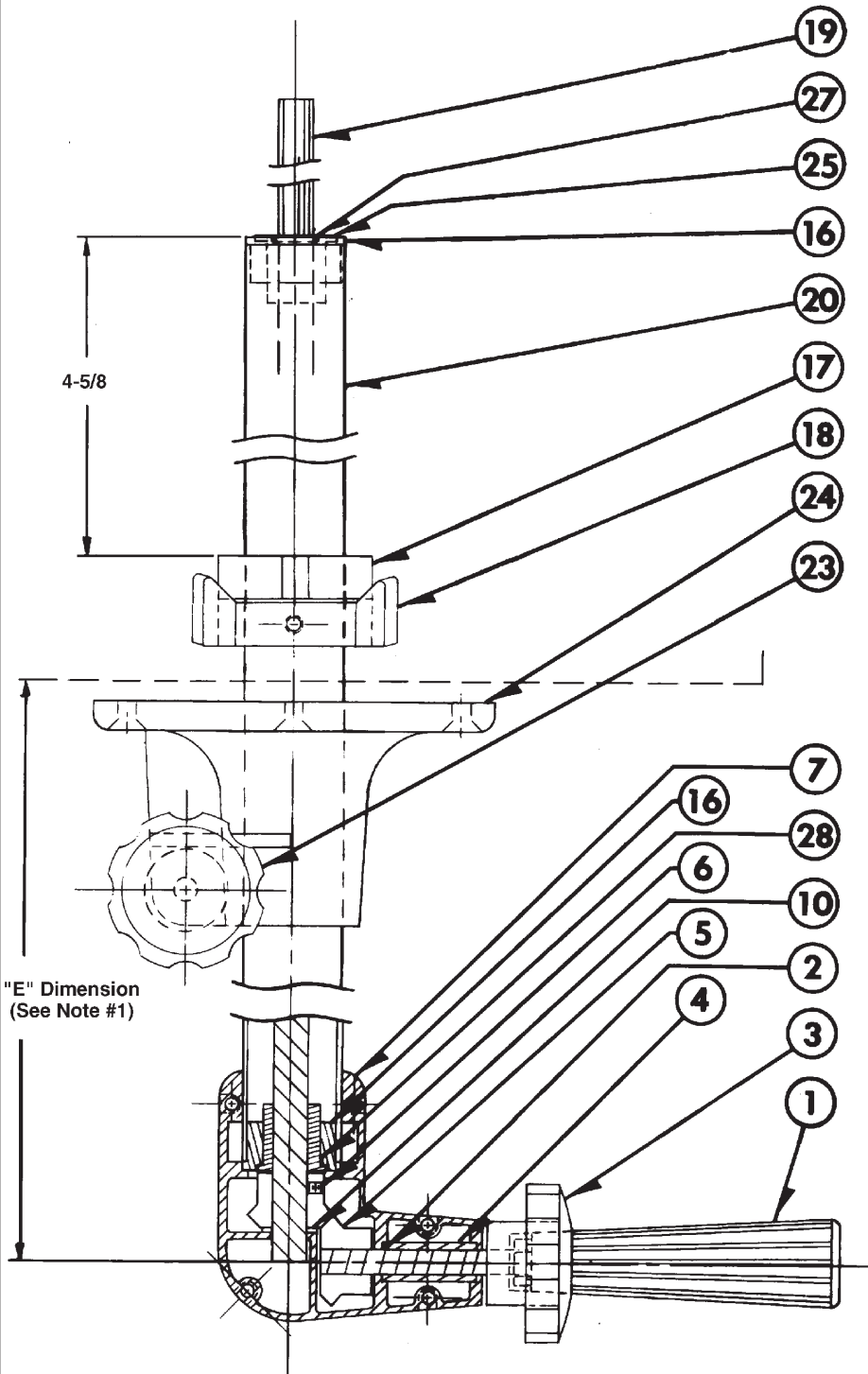

Fig. 1921 Lever/Gear Control Searchlight Control Assembly Instructions



Bill of Material

Item	Spare Part	Description	Qty.
1	0969SPR001	Control Handle (Plastic)	1
2	0969SPR002	Control Shaft, 3/8 IN. Dia., S.S	1
3	0969SPR003	Vertical Lock Knob	1
4	0969SPR004	Sleeve Bushing	1
5	0969SPR005	Control Gear 3/8 IN. Bore	1
6	0969SPR006	Control Gear 1/2 IN. Bore	1
7	0969SPR007	Control Housing With Screws	1
16	1921SPR016	Control Tube Spacer Bushing	2
10	0969SPR010	Thrust Washer (Plastic)	1
17		Floating Stop Collar	1
18		Fixed Stop Collar (See Note 2)	1
19		Vert. Control Rod (See Note 2)	1
20		Horiz. Control Tube	1
24		Horizontal Lock/Ceiling Plate	1
23		Lock Knob With Spacer	1
25	0851SPR025	Upper Control Tube Bushing	1
27	0851SPR027	O-Ring Seal	1
28	0851SPR028	Lower Control Tube Bushing	1

Note 1:

For Searchlight Fig. No.	Control Assy. Only Fig. No.	"E" Dimension
1902	1921	22"

Note 2:

LENGTHS OF VERTICAL CONTROL RODS AND HORIZONTAL CONTROL TUBES MUST BE SPECIFIED BY THE "E" DIMENSION AS SHOWN IN NOTE #1. IN ADDITION TO THE CONTROL ASSEMBLY FIG. NO. IN COLUMN TWO OF THE ABOVE CHART. OTHER DIMENSIONS ARE AVAILABLE ON SPECIAL ORDER BASIS.

"E" Dimension
(See Note #1)

PERKO®	
16490 N.W. 13th Avenue	Miami, FL 33169-5707
Date: 3-18-83	Drawn By: D. Beutler
Scale: None	Revised: 6/3/16
Fig. No. 1921 Series Searchlight Lever Gear Controls Fits: Fig. 1902 Series Searchlight Heads	



CAT. NO. 1902004WHT SOLAR-RAY® SEARCHLIGHT
Assembly and Installation Instructions
Wheel or Lever/Gear Control

- 1). Carefully unpack head and control assembly cartons. Place head assembly with lens down.
- 2). Remove pinion gear from inner rod on control assembly, by loosening set screw.
- 3). Examine head assembly and locate the two set screws 180° apart from each other on the bottom of the fork. DO NOT disturb the remaining (third) set screw opposite the zerk fitting.
- 4). Remove the two opposing set screws. Underneath each one is a second set screw (in the tapped hole). Back these out until they are flush with the surface.
- 5). **The horizontal stop collars on the Control Assembly are preset and should not be disturbed.** Make sure that the single ear on the upper collar is located between the two ears of the lower collar such that it is free to rotate back and forth in the smaller of the two angles formed by the lower two ears.
- 6). Insert the control assembly into the searchlight base. Make sure the outer tube has fully seated by removing one set screw from the fork and observing the tube pass the tapped hole. Replace the set screw and tighten both to secure the tube. Replace and tighten the outer set screw to provide a double lock.
- 7). Replace and tighten pinion gear onto inner control rod.
- 8). Remove the lever gear assembly by loosening the three set screws at the top of the casting. It is not necessary to detach the beveled gear from the inner control rod.
- 9). Remove the ceiling plate by loosening its knob and sliding it down off the end of the control assembly.
- 10). Drill a 1-5/8 inch diameter hole in roof to clear the outer control tube at the proper location. Drill a 3/4 inch diameter hole aft of the control hole for the electrical cable.
- 11). Working from above, mount the searchlight by lowering the control assembly through its hole in the roof. Properly locate the electrical cable, by making sure the cable strain relief gland on the base is on the aft side of the searchlight (for proper orientation of the port and starboard horizontal stops). Using the base as template, drill to accommodate 1/2 inch diameter stainless steel hex head bolts. Thru bolt the base to the roof.
- 12). Install the ceiling plate and lever gear assembly from below. Orient control handle with the direction of the head as desired.
- 13). Wire to applicable electrical standards and grease through all three zerk fittings.

Note: For information regarding bulbs, repair parts, or special construction, contact your local PERKO® distributor or PERKO, Inc. 16490 N.W. 13th Avenue, Miami, FL 33169-5707.